

CLASSIC II

Gelato Showcase

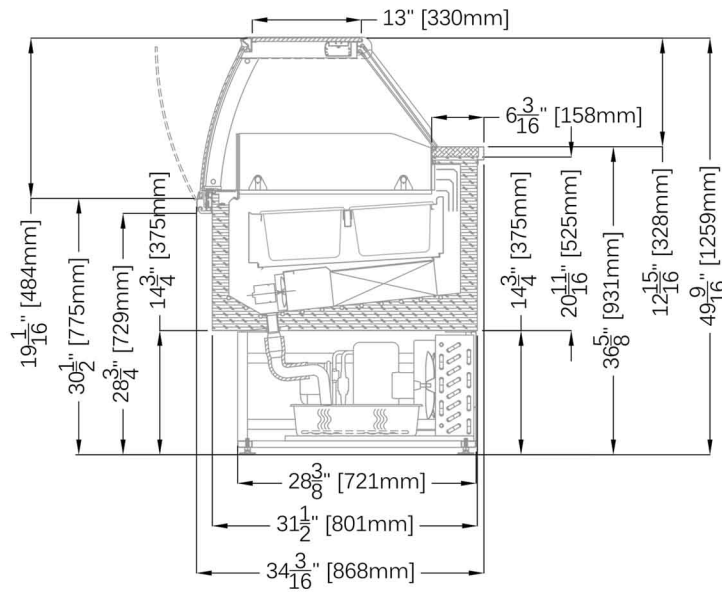

STANDARD FEATURES

- Stainless steel insulated body with tubular painted galvanized chassis
- Silver trim finish
- Dixell digital controller
- Air cooled condensing unit
- Temperature front and side glass single pane with anti fog serigraph
- Tilt back front glass
- LED lighting
- Plexiglass sliding doors
- Stainless steel work bench
- Cases ship standard unfinished front and stainless steel skin sides

OPTIONS

- Champagne trim finish
- Stainless steel inserts and pans
- Round tubs
- Dip well
- Cone holder
- Frozen cake stainless steel trays
- Dual temperature zone
- Marble/granite work counter
- RAL color finish/wood laminate
- Roll down curtain
- Remote/water cooled unit
- Matching front cabinetry counters with top glass
- Canopy lighting
- Casters

CLASSIC II GELATO					
TECHNICAL FEATURES		MODELS			
		CLASSIC II CIIG1150	CLASSIC II CIIG1650	CLASSIC II CIIG2150	CLASSIC II CIIG2150 DUAL TEMP
External Dimensions (L-D-H)	Inches	45 1/4" - 34 3/16" - 49 9/16"	64 15/16" - 34 3/16" - 49 9/16"	84 5/8" - 34 3/16" - 49 9/16"	84 5/8" - 34 3/16" - 49 9/16"
	Inches-MM	*1150 - 868 - 1259	*1650 - 868 - 1259	*2150 - 868 - 1259	*2150 - 868 - 1259
Crated Dimensions (L-D-H)	Inches	52" - 41" - 55"	70" - 41" - 55"	91" - 41" - 55"	91" - 41" - 55"
	Inches-MM	1320 - 1041 - 1397	1778 - 1041 - 1397	2311 - 1041 - 1397	2311 - 1041 - 1397
2.5 & 5 Liter Pan Capacity**	Pan Configuration	6 (2.5 LITER) + 6 (5 LITER)	9 (2.5 LITER) + 9 (5 LITER)	12 (2.5 LITER) + 12 (5 LITER)	12 (2.5 LITER) + 12 (5 LITER)
7 1/16" x 6 1/2" x 4 3/4" (180mm x 165mm x 120mm)					
14 3/16" x 6 1/2" x 4 3/4" (360mm x 165mm x 120mm)					
4 Liter Pan Capacity**	Pan Configuration	12	18	24	24
10 1/8" x 6 1/8" x 5 7/8" (258mm x 156mm x 150mm)					
5 Liter Pan Capacity**	Pan Configuration	8	13	16	N/A
14 3/16" x 6 1/2" x 4 3/4" (360mm x 165mm x 120mm)					
8 Liter Pan Capacity**	Pan Configuration	4	8	10	N/A
14 3/16" x 9 13/16" x 4 3/4" (360mm x 250mm x 120mm)					
Refrigeration	Type	Fan Ventilated	Fan Ventilated	Fan Ventilated	Fan Ventilated
Refrigeration Display Area	Type	Deck	Deck	Deck	Deck
Operating Temperature	°C / °F	-18°C / -0.4°F	-18°C / -0.4°F	-18°C / -0.4°F	-18°C / -0.4°F
Compressor	Nr./Type	1 / Hermetic	1 / Hermetic	1 / Hermetic	1 / Hermetic
Electric Supply	(V/Ph/Hz)	230/1/50 (EU) 208/220V/1/60 (USA)	230/1/50 (EU) 208/220V/1/60 (USA)	230/1/50 (EU) 208/220V/1/60 (USA)	230/1/50 (EU) 208/220V/1/60 (USA)
BTU'S @ -25°F		2150 BTU'S	3580 BTU'S	4550 BTU'S	10,880 BTU'S
Evap Temperature					
Power Consumption	(W/A)	1500W / 7.5A	1720W / 11A	2050W / 10.5A	2050W / 10.5A
Defrost	Mode/Type	Hot Gas	Hot Gas	Hot Gas	Hot Gas
Climatic Class	N°/°C/°F°/H.R.	4/30/86/55%	4/30/86/55%	4/30/86/55%	4/30/86/55%
Refrigerant Gas	Type	R404A	R404A	R404A	R404A
Net Weights	Kg/Lb	165Kgs / 363Lbs	220Kgs / 484Lbs	274Kgs / 602Lbs	274Kgs / 602Lbs
Crated Weights	Kg/Lb	265Kgs / 583Lbs	340Kgs / 748Lbs	420Kgs / 924Lbs	420Kgs / 924Lbs

* DIMENSIONS ARE WITHOUT SIDE PANELS ** PANS NOT INCLUDED

* Manufacturer reserves the right to change specifications without notice. Not responsible for error and omissions.



361-367 Beach Road, Burlingame, CA 94010
 Tel: 855.885.2400 | 650.342.2400 | Fax: 650.342.7400
 sales@oscartek.com | www.oscartek.com

