



Discover the Art of Display...

Project Name: _____
Item #: _____ Quantity: _____

STANDARD FEATURES

- Available in 3 heights: 47”H, 53”H, and 59”H
- Humidity control
- Chrome finishing
- Diamond 1 All Models: Refrigerated deck + shelf. Low heated front glass.
- Diamond 2 All Models: Refrigerated deck + lower shelf. Top shelf non-refrigerated. Low heated front glass.
- Diamond 3 All Models: Refrigerated deck + lower shelf. Top (2) shelves non-refrigerated. Low heated front glass.
- Diffused LED lighting 3000°K
- Electric control board
- Electric defrost
- Front glass with safety tilt down opening system
- Pyrolytic anti-fog front and side glass
- Cases ship standard unfinished front and stainless steel skin sides

OPTIONS

- Remote condensing unit
- Work top (brushed s/s, corian, granite)
- Stainless steel step shelf
- Epoxy RAL color interior and exterior over stainless steel
- RAL color/custom plastic wood laminate exterior front and sides
- Unfinished panels to accept millwork by others
- Condensate heated pan
- Casters

DIAMOND 1-2-3

Chocolate Showcase

DIAMOND 1 CHOCOLATE MODELS: DIAMOND 1 C1110, DIAMOND 1 C1610, DIAMOND 1 C2106, DIAMOND 1 CA30, DIAMOND 1 CC30

DIAMOND 2 CHOCOLATE MODELS: DIAMOND 2 C1110, DIAMOND 2 C1610, DIAMOND 2 C2106, DIAMOND 2 CA30, DIAMOND 2 CC30

DIAMOND 3 CHOCOLATE MODELS: DIAMOND 3 C1110, DIAMOND 3 C1610, DIAMOND 3 C2106, DIAMOND 3 CA30, DIAMOND 3 CC30



Diamond 2 Chocolate 30° cases with optional front RAL color finish



Visit our website for more finishing options and RAL colors
www.oscartek.com

*Oscartek reserves the right to change, modify, discontinue, or change any features, sizes, or capacity on any model without prior notice.

OSCARTEK®
512 South Airport Blvd., South San Francisco, CA 94080
Tel: 650.342.2400 | Fax: 650.342.7400
www.oscartek.com



DIAMOND 1-2-3 CHOCOLATE

DIAMOND 1 CHOCOLATE MODELS: DIAMOND 1 C1110, DIAMOND 1 C1610, DIAMOND 1 C2106, DIAMOND 1 CA30, DIAMOND 1 CC30

DIAMOND 2 CHOCOLATE MODELS: DIAMOND 2 C1110, DIAMOND 2 C1610, DIAMOND 2 C2106, DIAMOND 2 CA30, DIAMOND 2 CC30

DIAMOND 3 CHOCOLATE MODELS: DIAMOND 3 C1110, DIAMOND 3 C1610, DIAMOND 3 C2106, DIAMOND 3 CA30, DIAMOND 3 CC30

STANDARD: DIAMOND 1-2-3 CHOCOLATE

PLAN VIEWS

DIAMOND 1-2-3 C1110

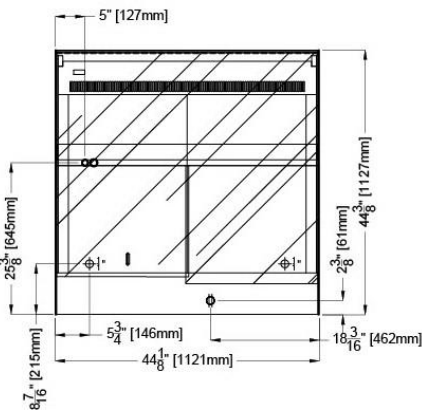

DIAMOND 1-2-3 C1610

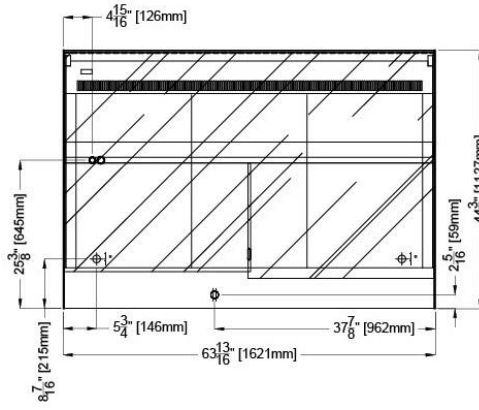

DIAMOND 1-2-3 C2106

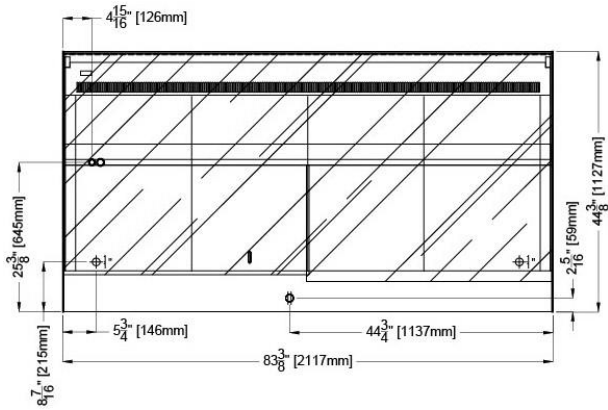

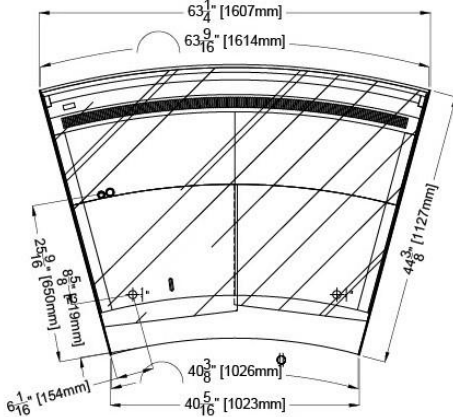

DIAMOND 1-2-3 CA30

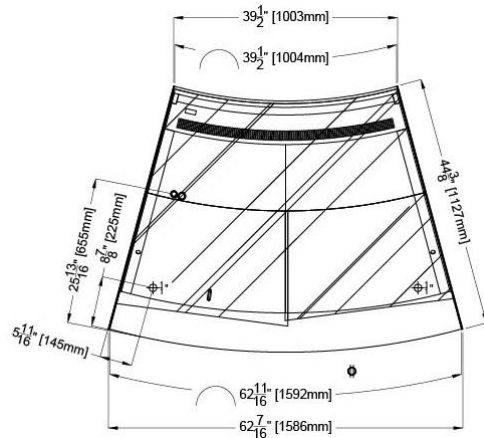

DIAMOND 1-2-3 CC30



ELECTRICAL LEGEND

	REFRIGERATION LINES
	DRAIN
	POWER

*Oscartek reserves the right to change, modify, discontinue, or change any features, sizes, or capacity on any model without prior notice.

OSCARTEK®

512 South Airport Blvd., South San Francisco, CA 94080

Tel: 650.342.2400 | Fax: 650.342.7400

www.oscartek.com





Discover the Art of Display...

Project Name: _____

Item #: _____ Quantity: _____

DIAMOND 1-2-3 CHOCOLATE

DIAMOND 1 CHOCOLATE MODELS: DIAMOND 1 C1110, DIAMOND 1 C1610, DIAMOND 1 C2106, DIAMOND 1 CA30, DIAMOND 1 CC30

DIAMOND 2 CHOCOLATE MODELS: DIAMOND 2 C1110, DIAMOND 2 C1610, DIAMOND 2 C2106, DIAMOND 2 CA30, DIAMOND 2 CC30

DIAMOND 3 CHOCOLATE MODELS: DIAMOND 3 C1110, DIAMOND 3 C1610, DIAMOND 3 C2106, DIAMOND 3 CA30, DIAMOND 3 CC30

STANDARD: DIAMOND 1-2-3 CHOCOLATE

REAR ELEVATIONS (OPERATOR SIDE)

DIAMOND 1-2-3 C1110, C1610, C2106

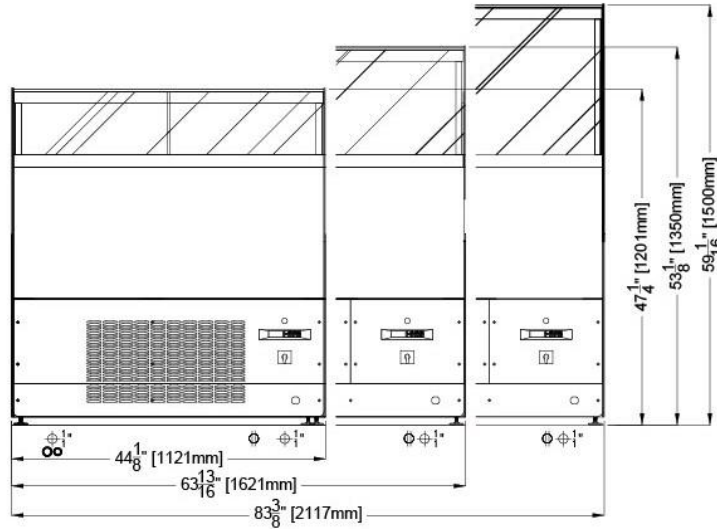

OPTIONAL: CUSTOM DIAMOND CA30 WITH COLD STORAGE DRAWER

SECTION & PLAN VIEWS

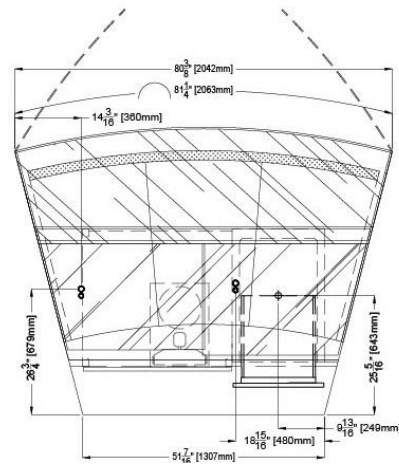
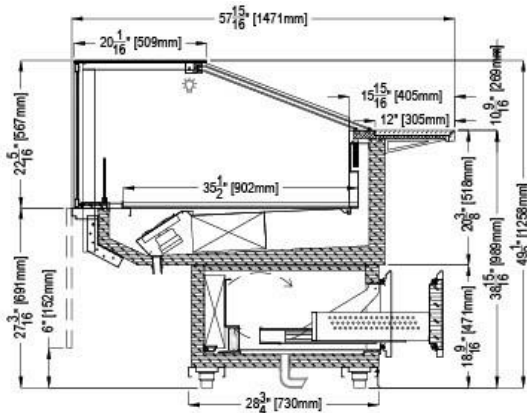

*Oscartek reserves the right to change, modify, discontinue, or change any features, sizes, or capacity on any model without prior notice.

OSCARTEK®
512 South Airport Blvd., South San Francisco, CA 94080
Tel: 650.342.2400 | Fax: 650.342.7400
www.oscartek.com



DIAMOND 1-2-3 CHOCOLATE

DIAMOND 1 CHOCOLATE MODELS: DIAMOND 1 C1110, DIAMOND 1 C1610, DIAMOND 1 C2106, DIAMOND 1 CA30, DIAMOND 1 CC30

DIAMOND 2 CHOCOLATE MODELS: DIAMOND 2 C1110, DIAMOND 2 C1610, DIAMOND 2 C2106, DIAMOND 2 CA30, DIAMOND 2 CC30

DIAMOND 3 CHOCOLATE MODELS: DIAMOND 3 C1110, DIAMOND 3 C1610, DIAMOND 3 C2106, DIAMOND 3 CA30, DIAMOND 3 CC30

STANDARD: DIAMOND 1-2-3 CHOCOLATE SECTION VIEWS

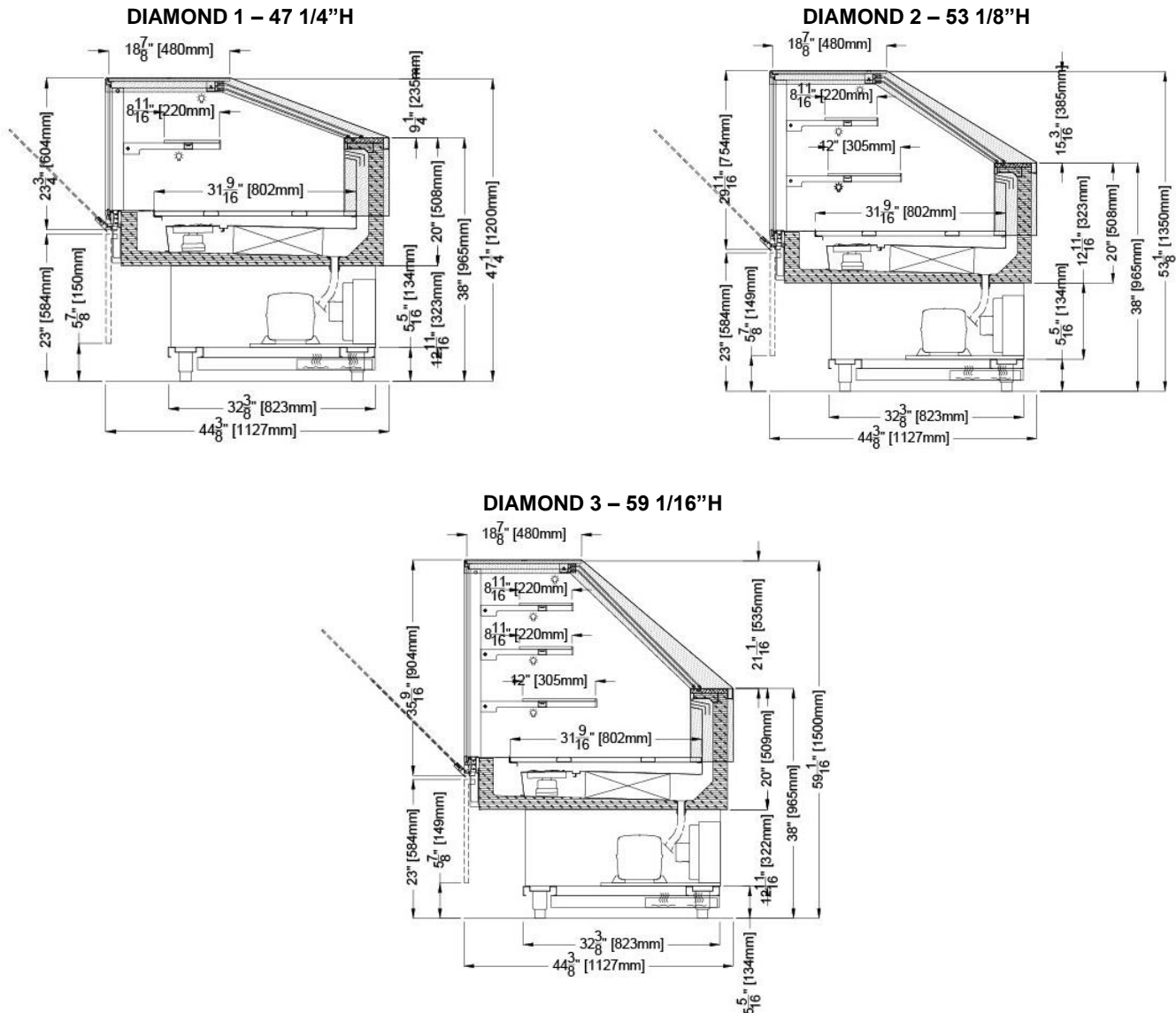

*Oscartek reserves the right to change, modify, discontinue, or change any features, sizes, or capacity on any model without prior notice.



Project Name: _____
 Item #: _____ Quantity: _____

DIAMOND 1-2-3 CHOCOLATE

DIAMOND 1 CHOCOLATE MODELS: DIAMOND 1 C1110, DIAMOND 1 C1610, DIAMOND 1 C2106, DIAMOND 1 CA30, DIAMOND 1 CC30

DIAMOND 2 CHOCOLATE MODELS: DIAMOND 2 C1110, DIAMOND 2 C1610, DIAMOND 2 C2106, DIAMOND 2 CA30, DIAMOND 2 CC30

DIAMOND 3 CHOCOLATE MODELS: DIAMOND 3 C1110, DIAMOND 3 C1610, DIAMOND 3 C2106, DIAMOND 3 CA30, DIAMOND 3 CC30

DIAMOND 1 CHOCOLATE						
TECHNICAL FEATURES		MODELS				
		DIAMOND 1 C1110	DIAMOND 1 C1610	DIAMOND 1 C2106	DIAMOND 1 CA30	DIAMOND 1 CC30
External Dimensions (L-D-H) Inches-MM	Inches MM	*44 1/8" - 44 3/8" - 47 1/4" *1121 - 1127 - 1200	*63 13/16" - 44 3/8" - 47 1/4" *1621 - 1127 - 1200	*83 3/8" - 44 3/8" - 47 1/4" *2117 - 1127 - 1200	*63 1/4" - 44 3/8" - 47 1/4" *1607 - 1127 - 1200	*62 7/16" - 44 3/8" - 47 1/4" *1590 - 1127 - 1200
Crated Dimensions (L-D-H) Inches-MM	Inches MM	52" - 52" - 53" 1320 - 1320 - 1346	70" - 52" - 53" 1778 - 1320 - 1346	90" - 52" - 53" 2286 - 1320 - 1346	70" - 52" - 53" 1778 - 1320 - 1346	70" - 52" - 53" 1778 - 1320 - 1346
Humidity Control	Type	35-70%	35-70%	35-70%	35-70%	35-70%
Refrigeration Display Area	Type	Deck + Shelf	Deck + Shelf	Deck + Shelf	Deck + Shelf	Deck + Shelf
Operating Temperature	°F	58°F	58°F	58°F	58°F	58°F
Compressor	Nr./Type	1 / Hermetic	1 / Hermetic	1 / Hermetic	1 / Hermetic	1 / Hermetic
Electric Supply	(V/Ph/Hz)	208-220/1/60	208-220/1/60	208-220/1/60	208-220/1/60	208-220/1/60
BTU'S @ +28°F Evap Temperature	BTU'S	3350	4500	5300	4500	4500
Power Consumption	(W/A)	1390/6,9	1700/8,5	2100/11,5	1700/8,5	1700/8,5
Defrost	Mode/Type	Electric	Electric	Electric	Electric	Electric
Climatic Class	°F/H.R.	75°F-55%RH	75°F-55%RH	75°F-55%RH	75°F-55%RH	75°F-55%RH
Refrigerant Gas	Type	R452A	R452A	R452A	R452A	R452A
Pipe Size (Inches)	Suction, Liquid	1/2", 1/4"	1/2", 1/4"	5/8", 5/16"	1/2", 1/4"	1/2", 1/4"
Net Weights	Lb	440	640	720	600	600
Crated Weights	Lb	530	740	830	700	700

*DIMENSIONS ARE WITH STANDARD POLISHED S/S SKIN SIDES

DIAMOND 2 CHOCOLATE						
TECHNICAL FEATURES		MODELS				
		DIAMOND 2 C1110	DIAMOND 2 C1610	DIAMOND 2 C2106	DIAMOND 2 CA30	DIAMOND 2 CC30
External Dimensions (L-D-H) Inches-MM	Inches MM	*44 1/8" - 44 3/8" - 53 1/8" *1121 - 1127 - 1350	*63 13/16" - 44 3/8" - 53 1/8" *1621 - 1127 - 1350	*83 3/8" - 44 3/8" - 53 1/8" *2117 - 1127 - 1350	*63 1/4" - 44 3/8" - 53 1/8" *1607 - 1127 - 1350	*62 7/16" - 44 3/8" - 53 1/8" *1590 - 1127 - 1350
Crated Dimensions (L-D-H) Inches-MM	Inches MM	52" - 52" - 61" 1320 - 1320 - 1549	70" - 52" - 61" 1778 - 1320 - 1549	90" - 52" - 61" 2286 - 1320 - 1549	70" - 52" - 61" 1778 - 1320 - 1549	70" - 52" - 61" 1778 - 1320 - 1549
Humidity Control	Type	35-70%	35-70%	35-70%	35-70%	35-70%
Refrigeration Display Area	Type	Deck + Lower Shelf	Deck + Lower Shelf	Deck + Lower Shelf	Deck + Lower Shelf	Deck + Lower Shelf
Operating Temperature	°C / °F	14°C / 58°F	14°C / 58°F	14°C / 58°F	14°C / 58°F	14°C / 58°F
Compressor	Nr./Type	1 / Hermetic	1 / Hermetic	1 / Hermetic	1 / Hermetic	1 / Hermetic
Electric Supply	(V/Ph/Hz)	208-220/1/60	208-220/1/60	208-220/1/60	208-220/1/60	208-220/1/60
BTU'S @ +28°F Evap Temperature	BTU'S	3350	4500	5300	4500	4500
Power Consumption	(W/A)	1390/6,9	1700/8,5	2100/11,5	1700/8,5	1700/8,5
Defrost	Mode/Type	Electric	Electric	Electric	Electric	Electric
Climatic Class	°F/H.R.	75°F-55%RH	75°F-55%RH	75°F-55%RH	75°F-55%RH	75°F-55%RH
Refrigerant Gas	Type	R452A	R452A	R452A	R452A	R452A
Pipe Size (Inches)	Suction, Liquid	1/2", 1/4"	1/2", 1/4"	5/8", 5/16"	1/2", 1/4"	1/2", 1/4"
Net Weights	Lb	450	650	730	610	610
Crated Weights	Lb	540	750	840	710	710

*DIMENSIONS ARE WITH STANDARD POLISHED S/S SKIN SIDES

*Oscartek reserves the right to change, modify, discontinue, or change any features, sizes, or capacity on any model without prior notice.

OSCARTEK®
 512 South Airport Blvd., South San Francisco, CA 94080
 Tel: 650.342.2400 | Fax: 650.342.7400
 www.oscartek.com





Project Name: _____
 Item #: _____ Quantity: _____

DIAMOND 1-2-3 CHOCOLATE

DIAMOND 1 CHOCOLATE MODELS: DIAMOND 1 C1110, DIAMOND 1 C1610, DIAMOND 1 C2106, DIAMOND 1 CA30, DIAMOND 1 CC30

DIAMOND 2 CHOCOLATE MODELS: DIAMOND 2 C1110, DIAMOND 2 C1610, DIAMOND 2 C2106, DIAMOND 2 CA30, DIAMOND 2 CC30

DIAMOND 3 CHOCOLATE MODELS: DIAMOND 3 C1110, DIAMOND 3 C1610, DIAMOND 3 C2106, DIAMOND 3 CA30, DIAMOND 3 CC30

DIAMOND 3 CHOCOLATE						
TECHNICAL FEATURES		MODELS				
		DIAMOND 3 C1110	DIAMOND 3 C1610	DIAMOND 3 C2106	DIAMOND 3 CA30	DIAMOND 3 CC30
External Dimensions (L-D-H) Inches-MM	Inches MM	*44 1/8" - 44 3/8" - 59 1/16" *1121 - 1127 - 1500	*63 13/16" - 44 3/8" - 59 1/16" *1621 - 1127 - 1500	*83 3/8" - 44 3/8" - 59 1/16" *2117 - 1127 - 1500	*63 1/4" - 44 3/8" - 59 1/16" *1607 - 1127 - 1500	*62 7/16" - 44 3/8" - 59 1/16" *1590 - 1127 - 1500
Crated Dimensions (L-D-H) Inches-MM	Inches MM	52" - 52" - 67" 1320 - 1320 - 1701	70" - 52" - 67" 1778 - 1320 - 1701	90" - 52" - 67" 2286 - 1320 - 1701	70" - 52" - 67" 1778 - 1320 - 1701	70" - 52" - 67" 1168 - 1320 - 1701
Humidity Control	Type	35-70%	35-70%	35-70%	35-70%	35-70%
Refrigeration Display Area	Type	Deck + Lower Shelf	Deck + Lower Shelf	Deck + Lower Shelf	Deck + Lower Shelf	Deck + Lower Shelf
Operating Temperature	°F	58°F	58°F	58°F	58°F	58°F
Compressor	Nr./Type	1 / Hermetic	1 / Hermetic	1 / Hermetic	1 / Hermetic	1 / Hermetic
Electric Supply	(V/Ph/Hz)	208-220/1/60	208-220/1/60	208-220/1/60	208-220/1/60	208-220/1/60
BTU'S @ +28°F Evap Temperature	BTU'S	3350	4500	5300	4500	4500
Power Consumption	(W/A)	1400/7,0	1800/8,9	2200/12,5	1750/8,9	1750/8,9
Defrost	Mode/Type	Electric	Electric	Electric	Electric	Electric
Climatic Class	°F/H.R.	75°F-55%RH	75°F-55%RH	75°F-55%RH	75°F-55%RH	75°F-55%RH
Refrigerant Gas	Type	R452A	R452A	R452A	R452A	R452A
Pipe Size (Inches)	Suction, Liquid	1/2", 1/4"	1/2", 1/4"	5/8", 5/16"	1/2", 1/4"	1/2", 1/4"
Net Weights	Lb	450	650	730	610	610
Crated Weights	Lb	540	750	840	710	710

*DIMENSIONS ARE WITH STANDARD POLISHED S/S SKIN SIDES

*Oscartek reserves the right to change, modify, discontinue, or change any features, sizes, or capacity on any model without prior notice.

OSCARTEK®
 512 South Airport Blvd., South San Francisco, CA 94080
 Tel: 650.342.2400 | Fax: 650.342.7400
 www.oscartek.com

