

DIAMOND PRO 1-2-3

Gelato/Ice Cream Showcase

STANDARD FEATURES

- Available in 3 heights 47”H, 53”H, and 59”H
- Chrome finishing
- Diffused LED lighting 3000°K
- Electric control board
- Reverse cycle defrost
- Double pane lift-up front glass
- Dixell digital control
- Illuminated flavor panel
- Pyrolytic anti-fog front and side glass
- Cases ship standard unfinished front and stainless steel skin sides

OPTIONS

- Remote condensing unit
- Work top (brushed s/s, corian, granite)
- Stainless steel or acrylic pans
- Stainless steel display trays for ice cream cakes
- Popsicle display tray (stainless steel & plastic: available in color options)
- Epoxy RAL color interior and exterior over stainless steel
- RAL color/custom plastic wood laminate exterior front and sides
- Unfinished panels to accept millwork by others
- Condensate heated pan
- Dipper well
- Cone holder
- Casters

DIAMOND PRO 1 GELATO/ICE CREAM: DIAMOND PRO 1 G1150, DIAMOND PRO 1 G1650, DIAMOND PRO 1 G2150, DIAMOND PRO 1 G2150 Dual Temp
DIAMOND PRO 2 GELATO/ICE CREAM: DIAMOND PRO 2 G1150, DIAMOND PRO 2 G1650, DIAMOND PRO 2 G2150, DIAMOND PRO 2 G2150 Dual Temp
DIAMOND PRO 3 GELATO/ICE CREAM: DIAMOND PRO 3 G1150, DIAMOND PRO 3 G1650, DIAMOND PRO 3 G2150, DIAMOND PRO 3 G2150 Dual Temp



Diamond Pro 2 optional RAL color finish front and sides

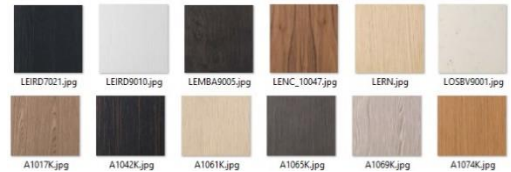

Visit our website for more finishing options and RAL colors
www.oscartek.com

*Oscartek reserves the right to change, modify, discontinue, or change any features, sizes, or capacity on any model without prior notice.

DIAMOND PRO 1-2-3 GELATO/ICE CREAM

DIAMOND PRO 1 GELATO/ICE CREAM: DIAMOND PRO 1 G1150, DIAMOND PRO 1 G1650, DIAMOND PRO 1 G2150, DIAMOND PRO 1 G2150 Dual Temp

DIAMOND PRO 2 GELATO/ICE CREAM: DIAMOND PRO 2 G1150, DIAMOND PRO 2 G1650, DIAMOND PRO 2 G2150, DIAMOND PRO 2 G2150 Dual Temp

DIAMOND PRO 3 GELATO/ICE CREAM: DIAMOND PRO 3 G1150, DIAMOND PRO 3 G1650, DIAMOND PRO 3 G2150, DIAMOND PRO 3 G2150 Dual Temp

STANDARD: DIAMOND PRO 1-2-3 GELATO/ICE CREAM

PLAN VIEWS

DIAMOND PRO 1-2-3 G1150

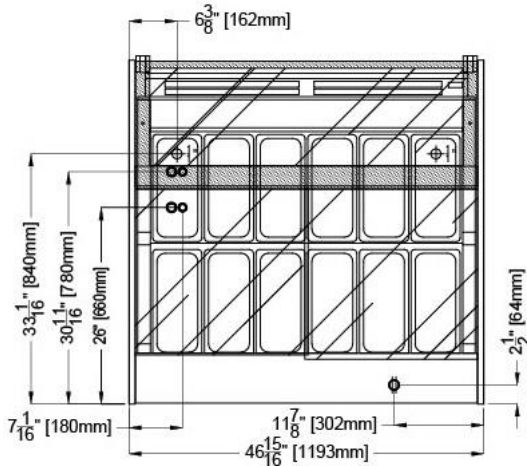

DIAMOND PRO 1-2-3 G1650

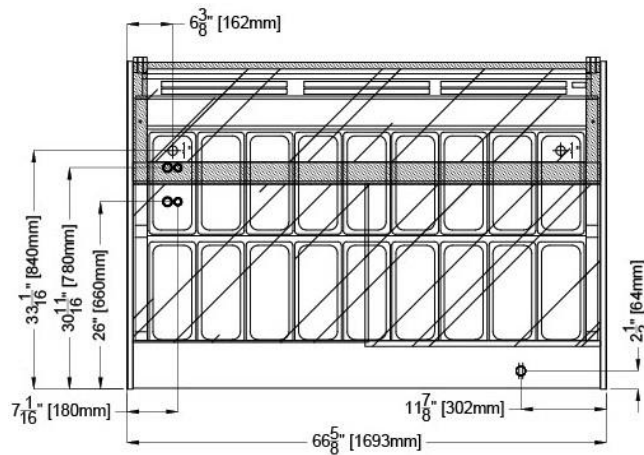

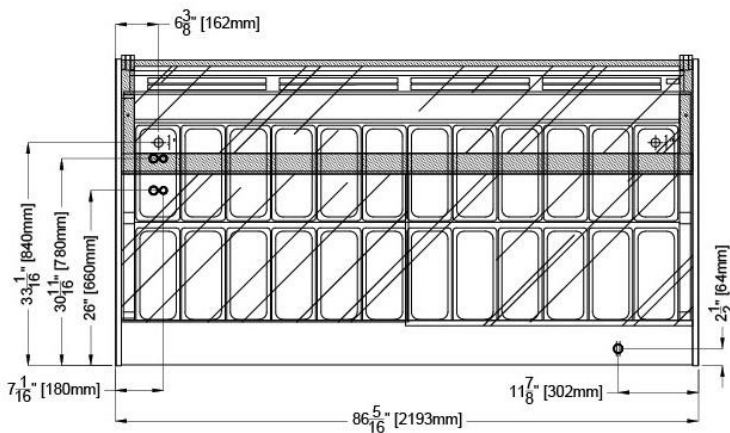

DIAMOND PRO 1-2-3 G2150

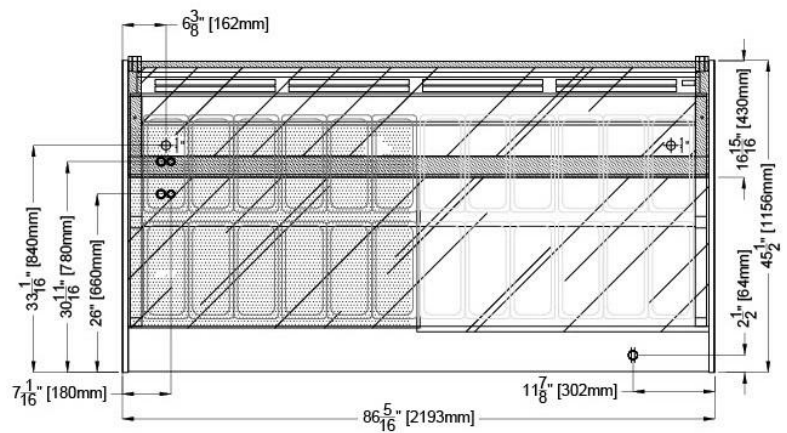

DIAMOND PRO 1-2-3 G2150 Dual Temp



ELECTRICAL LEGEND

	REFRIGERATION LINES
	DRAIN
	POWER

*Oscartek reserves the right to change, modify, discontinue, or change any features, sizes, or capacity on any model without prior notice.

OSCARTEK®

512 South Airport Blvd., South San Francisco, CA 94080

Tel: 650.342.2400 | Fax: 650.342.7400

www.oscartek.com



DIAMOND PRO 1-2-3 GELATO/ICE CREAM

DIAMOND PRO 1 GELATO/ICE CREAM: DIAMOND PRO 1 G1150, DIAMOND PRO 1 G1650, DIAMOND PRO 1 G2150, DIAMOND PRO 1 G2150 Dual Temp

DIAMOND PRO 2 GELATO/ICE CREAM: DIAMOND PRO 2 G1150, DIAMOND PRO 2 G1650, DIAMOND PRO 2 G2150, DIAMOND PRO 2 G2150 Dual Temp

DIAMOND PRO 3 GELATO/ICE CREAM: DIAMOND PRO 3 G1150, DIAMOND PRO 3 G1650, DIAMOND PRO 3 G2150, DIAMOND PRO 3 G2150 Dual Temp

STANDARD: DIAMOND PRO 1-2-3 GELATO/ICE CREAM

REAR ELEVATIONS (OPERATOR SIDE)

DIAMOND PRO 1-2-3 G1150, G1650, G2150

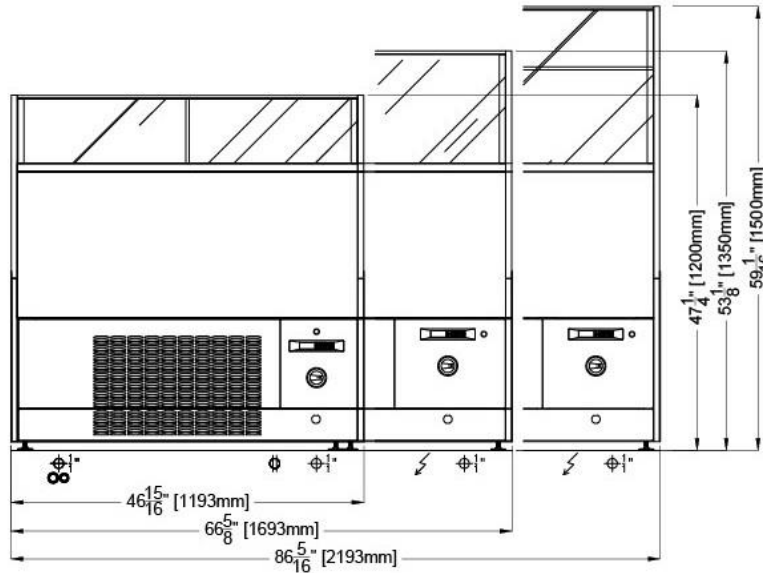

DIAMOND PRO 1-2-3 G2150 Dual Temp

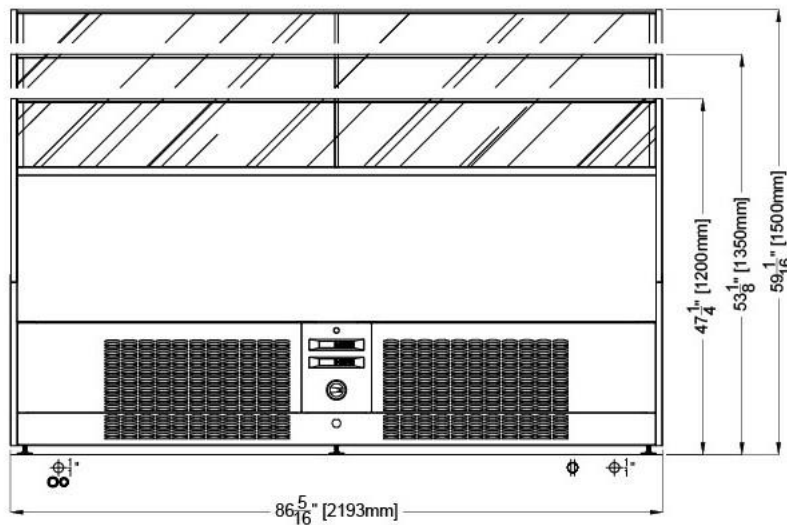

*Oscartek reserves the right to change, modify, discontinue, or change any features, sizes, or capacity on any model without prior notice.

DIAMOND PRO 1-2-3 GELATO/ICE CREAM

DIAMOND PRO 1 GELATO/ICE CREAM: DIAMOND PRO 1 G1150, DIAMOND PRO 1 G1650, DIAMOND PRO 1 G2150, DIAMOND PRO 1 G2150 Dual Temp

DIAMOND PRO 2 GELATO/ICE CREAM: DIAMOND PRO 2 G1150, DIAMOND PRO 2 G1650, DIAMOND PRO 2 G2150, DIAMOND PRO 2 G2150 Dual Temp

DIAMOND PRO 3 GELATO/ICE CREAM: DIAMOND PRO 3 G1150, DIAMOND PRO 3 G1650, DIAMOND PRO 3 G2150, DIAMOND PRO 3 G2150 Dual Temp

STANDARD: DIAMOND PRO 1-2-3 GELATO/ICE CREAM

SECTION VIEWS

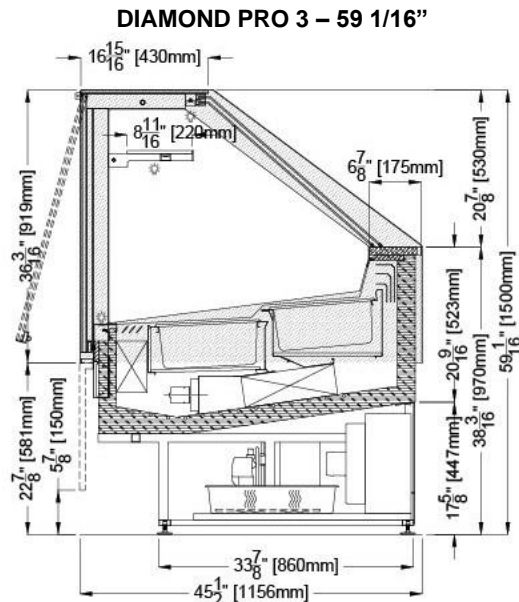
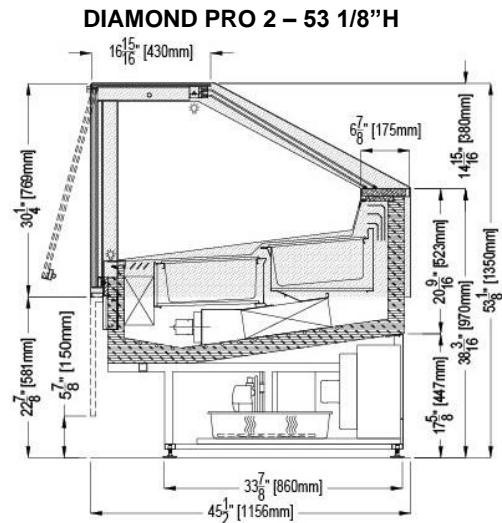
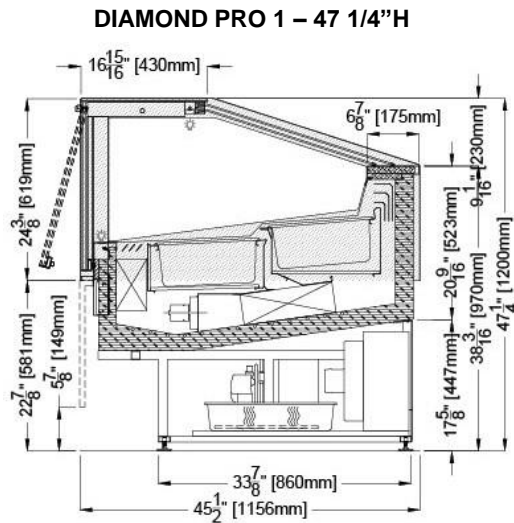

*Oscartek reserves the right to change, modify, discontinue, or change any features, sizes, or capacity on any model without prior notice.





Project Name: _____
 Item #: _____ Quantity: _____

DIAMOND PRO 1-2-3 GELATO/ICE CREAM

DIAMOND PRO 1 GELATO/ICE CREAM: DIAMOND PRO 1 G1150, DIAMOND PRO 1 G1650, DIAMOND PRO 1 G2150, DIAMOND PRO 1 G2150 Dual Temp

DIAMOND PRO 2 GELATO/ICE CREAM: DIAMOND PRO 2 G1150, DIAMOND PRO 2 G1650, DIAMOND PRO 2 G2150, DIAMOND PRO 2 G2150 Dual Temp

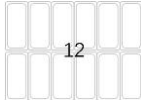
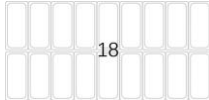
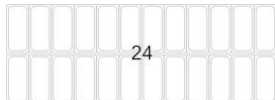
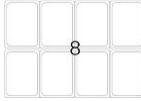
DIAMOND PRO 3 GELATO/ICE CREAM: DIAMOND PRO 3 G1150, DIAMOND PRO 3 G1650, DIAMOND PRO 3 G2150, DIAMOND PRO 3 G2150 Dual Temp

DIAMOND PRO 1 GELATO/ICE CREAM				
TECHNICAL FEATURES		MODELS		
		DIAMOND PRO 1 G1150 (DMD1PROGL45)	DIAMOND PRO 1 G1650 (DMD1PROGL64)	DIAMOND PRO 1 G2150 (DMD1PROGL84)
External Dimensions (L-D-H) Inches-MM	Inches MM	* 46 15/16" - 45 1/2" - 47 1/4" *1193 - 1155 - 1200	* 66 5/8" - 45 1/2" - 47 1/4" *1693 - 1155 - 1200	* 86 5/16" - 45 1/2" - 47 1/4" *2193 - 1155 - 1200
Crated Dimensions (L-D-H) Inches-MM	Inches MM	54" - 52" - 53" 1372 - 1320 - 1346	74" - 52" - 53" 1880 - 1320 - 1346	93" - 52" - 53" 2362 - 1320 - 1346
5 Liter Pan Capacity* 14 3/16" x 6 1/2" x 4 3/4" (360mm x 165mm x 120mm)	Pan Configuration			
8 Liter Pan Capacity* 14 3/16" x 9 13/16" x 4 3/4" (360mm x 250mm x 120mm)	Pan Configuration			
Refrigeration	Type	Fan Ventilated	Fan Ventilated	Fan Ventilated
Refrigeration Display Area	Type	Deck	Deck	Deck
Operating Temperature	°F	-0.4°F	-0.4°F	-0.4°F
Compressor	Nr./Type	1 / Semi-Hermetic	1 / Semi-Hermetic	1 / Semi-Hermetic
Electric Supply	(V/Ph/Hz)	208-220/3/60	208-220/3/60	208-220/3/60
BTU'S @ -31°F Evap Temperature	BTU'S	2730	3900	4900
Power Consumption	(W/A)	1900/7.0	3000/10.5	3200/13.0
Defrost	Mode/Type	Reverse Cycle	Reverse Cycle	Reverse Cycle
Climatic Class	°F/H.R.	75°F-55%RH	75°F-55%RH	75°F-55%RH
Refrigerant Gas	Type	R404A / R452A	R404A / R452A	R404A / R452A
Pipe Size (mm)	Suction, Liquid	18 / 10	22 / 10	22 / 10
Net Weights	Lb	510	715	820
Crated Weights	Lb	610	815	920
* DIMENSIONS ARE WITH STANDARD POLISHED S/S SKIN SIDES		** PANS NOT INCLUDED		

*Oscartek reserves the right to change, modify, discontinue, or change any features, sizes, or capacity on any model without prior notice.

OSCARTEK®
 512 South Airport Blvd., South San Francisco, CA 94080
 Tel: 650.342.2400 | Fax: 650.342.7400
 www.oscartek.com











Project Name: _____
 Item #: _____ Quantity: _____

DIAMOND PRO 1-2-3 GELATO/ICE CREAM

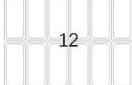
DIAMOND PRO 1 GELATO/ICE CREAM: DIAMOND PRO 1 G1150, DIAMOND PRO 1 G1650, DIAMOND PRO 1 G2150, DIAMOND PRO 1 G2150 Dual Temp

DIAMOND PRO 2 GELATO/ICE CREAM: DIAMOND PRO 2 G1150, DIAMOND PRO 2 G1650, DIAMOND PRO 2 G2150, DIAMOND PRO 2 G2150 Dual Temp

DIAMOND PRO 3 GELATO/ICE CREAM: DIAMOND PRO 3 G1150, DIAMOND PRO 3 G1650, DIAMOND PRO 3 G2150, DIAMOND PRO 3 G2150 Dual Temp

DIAMOND PRO 2 GELATO/ICE CREAM				
TECHNICAL FEATURES		MODELS		
		DIAMOND PRO 2 G1150 (DMD2PROGL45)	DIAMOND PRO 2 G1650 (DMD2PROGL64)	DIAMOND PRO 2 G2150 (DMD2PROGL84)
External Dimensions (L-D-H) Inches-MM	Inches MM	* 46 15/16" - 45 1/2" - 53 1/8" *1193 - 1155 - 1350	* 66 5/8" - 45 1/2" - 53 1/8" *1693 - 1155 - 1350	* 86 5/16" - 45 1/2" - 53 1/8" *2193 - 1155 - 1350
Crated Dimensions (L-D-H) Inches-MM	Inches MM	54" - 52" - 61" 1372 - 1320 - 1549	73" - 52" - 61" 1854 - 1320 - 1549	93" - 52" - 61" 2362 - 1320 - 1549
5 Liter Pan Capacity* 14 3/16" x 6 1/2" x 4 3/4" (360mm x 165mm x 120mm)	Pan Configuration			
8 Liter Pan Capacity* 14 3/16" x 9 13/16" x 4 3/4" (360mm x 250mm x 120mm)	Pan Configuration			
Refrigeration	Type	Fan Ventilated	Fan Ventilated	Fan Ventilated
Refrigeration Display Area	Type	Deck	Deck	Deck
Operating Temperature	°F	-0.4°F	-0.4°F	-0.4°F
Compressor	Nr./Type	1 / Semi-Hermetic	1 / Semi-Hermetic	1 / Semi-Hermetic
Electric Supply	(V/Ph/Hz)	208-220/3/60	208-220/3/60	208-220/3/60
BTU'S @ -31°F Evap Temperature	BTU'S	2730	3900	4900
Power Consumption	(W/A)	1900/7.0	3000/10.5	3200/13.0
Defrost	Mode/Type	Reverse Cycle	Reverse Cycle	Reverse Cycle
Climatic Class	°F/H.R.	75°F-55%RH	75°F-55%RH	75°F-55%RH
Refrigerant Gas	Type	R404A / R452A	R404A / R452A	R404A / R452A
Pipe Size (mm)	Suction, Liquid	18 / 10	22 / 10	22 / 10
Net Weights	Lb	570	725	890
Crated Weights	Lb	660	825	995
* DIMENSIONS ARE WITH STANDARD POLISHED S/S SKIN SIDES			** PANS NOT INCLUDED	

*Oscartek reserves the right to change, modify, discontinue, or change any features, sizes, or capacity on any model without prior notice.

OSCARTEK®
 512 South Airport Blvd., South San Francisco, CA 94080
 Tel: 650.342.2400 | Fax: 650.342.7400
 www.oscartek.com





Project Name: _____
 Item #: _____ Quantity: _____

DIAMOND PRO 1-2-3 GELATO/ICE CREAM

DIAMOND PRO 1 GELATO/ICE CREAM: DIAMOND PRO 1 G1150, DIAMOND PRO 1 G1650, DIAMOND PRO 1 G2150, DIAMOND PRO 1 G2150 Dual Temp

DIAMOND PRO 2 GELATO/ICE CREAM: DIAMOND PRO 2 G1150, DIAMOND PRO 2 G1650, DIAMOND PRO 2 G2150, DIAMOND PRO 2 G2150 Dual Temp

DIAMOND PRO 3 GELATO/ICE CREAM: DIAMOND PRO 3 G1150, DIAMOND PRO 3 G1650, DIAMOND PRO 3 G2150, DIAMOND PRO 3 G2150 Dual Temp

DIAMOND PRO 3 GELATO/ICE CREAM				
TECHNICAL FEATURES		MODELS		
		DIAMOND PRO 3 G1150 (DMD3PROGL45)	DIAMOND PRO 3 G1650 (DMD3PROGL64)	DIAMOND PRO 3 G2150 (DMD3PROGL84)
External Dimensions (L-D-H) Inches-MM	Inches MM	* 46 15/16" - 45 1/2" - 59 1/16" *1193 - 1155 - 1500	* 66 5/8" - 45 1/2" - 59 1/16" *1693 - 1155 - 1500	* 86 5/16" - 45 1/2" - 59 1/16" *2193 - 1155 - 1500
Crated Dimensions (L-D-H) Inches-MM	Inches MM	53" - 52" - 67" 1346 - 1320 - 1701	73" - 52" - 67" 1854 - 1320 - 1701	93" - 52" - 67" 2362 - 1320 - 1701
5 Liter Pan Capacity* 14 3/16" x 6 1/2" x 4 3/4" (360mm x 165mm x 120mm)	Pan Configuration			
8 Liter Pan Capacity* 14 3/16" x 9 13/16" x 4 3/4" (360mm x 250mm x 120mm)	Pan Configuration			
Refrigeration	Type	Fan Ventilated	Fan Ventilated	Fan Ventilated
Refrigeration Display Area	Type	Deck	Deck	Deck
Operating Temperature	°F	-0.4°F	-0.4°F	-0.4°F
Compressor	Nr./Type	1 / Semi-Hermetic	1 / Semi-Hermetic	1 / Semi-Hermetic
Electric Supply	(V/Ph/Hz)	208-220/3/60	208-220/3/60	208-220/3/60
BTU'S @ -31°F Evap Temperature	BTU'S	2730	3900	4900
Power Consumption	(W/A)	1950/7.3	3100/11,0	3300/13.9
Defrost	Mode/Type	Reverse Cycle	Reverse Cycle	Reverse Cycle
Climatic Class	°F/H.R.	75°F-55%RH	75°F-55%RH	75°F-55%RH
Refrigerant Gas	Type	R404A / R452A	R404A / R452A	R404A / R452A
Pipe Size (Inches)	Suction, Liquid	18 / 10	22 / 10	22 / 10
Net Weights	Lb	580	735	895
Crated Weights	Lb	670	835	1000
* DIMENSIONS ARE WITH STANDARD POLISHED S/S SKIN SIDES			** PANS NOT INCLUDED	

*Oscartek reserves the right to change, modify, discontinue, or change any features, sizes, or capacity on any model without prior notice.

OSCARTEK®
 512 South Airport Blvd., South San Francisco, CA 94080
 Tel: 650.342.2400 | Fax: 650.342.7400
 www.oscartek.com

