

### STANDARD FEATURES

- Double pane lift-up front glass
- Double pane sides
- Lift-up deck and evaporator to allow the perfect cleaning of the tank
- Diffused LED lighting 3000°K
- Plexiglass sliding doors
- Internal condensing unit
- Cases ship standard unfinished

### OPTIONS

- Bumper addition for cart/trolley
- Rolling curtain
- Paper holder
- Pull-out faucet inside the tank
- Cutting board with knives pocket
- Scale holder
- External condensing unit
- Intermediate shelf
- RAL color/laminate front and side panels
- Casters



LA CROSSE DELI/PASTRY					
TECHNICAL FEATURES		MODELS			
		LA CROSSE DP1150	LA CROSSE DP1650	LA CROSSE DP2150	LA CROSSE DPA90
External Dimensions (L-D-H)	Inches	*46 7/8" - 45 3/8" - 45 1/4"	*66 9/16" - 45 3/8" - 45 1/4"	*86 1/4" - 45 3/8" - 45 1/4"	*63 5/8" - 45 3/8" - 45 1/4"
	Inches-MM	*1190 - 1152 - 1150	*1690 - 1152 - 1150	*2190 - 1152 - 1150	*1616 - 1152 - 1150
Crated Dimensions (L-D-H)	Inches	53 7/8" - 53 7/8" - 55 1/8"	73 5/8" - 53 7/8" - 55 1/8"	93 1/4" - 53 7/8" - 55 1/8"	70" - 53 7/8" - 55 1/8"
	Inches-MM	1370 - 1370 - 1400	1870 - 1370 - 1400	2368 - 1370 - 1400	1778 - 1370 - 1400
Refrigeration	Type	Ventilated	Ventilated	Ventilated	Ventilated
Refrigeration Display Area	Type	Deck	Deck	Deck	Deck
Operating Temperature	°C / °F	2°C / 35°F	2°C / 35°F	2°C / 35°F	2°C / 35°F
Compressor	Nr./Type	1 / Hermetic	1 / Hermetic	1 / Hermetic	1 / Hermetic
BTU's @ +14°F Evap Temperature	BTU's	2400 BTU'S	3330 BTU'S	3625 BTU'S	5200 BTU'S
Electric Supply	(V/Ph/Hz)	230/1/50 (EU) 120/1/60 (USA)	230/1/50 (EU) 120/1/60 (USA)	230/1/50 (EU) 120/1/60 (USA)	230/1/50 (EU) 120/1/60 (USA)
Power Consumption	(W/A)	420W / 2.5A	650W / 4A	850W / 4.5A	1050W / 6A
Defrost	Mode/Type	Electric	Electric	Electric	Electric
Climatic Class	N°/°C/°F°/H.R.	3/25/77/60%	3/25/77/60%	3/25/77/60%	3/25/77/60%
Refrigerant Gas	Type	R404A	R404A	R404A	R404A
Net Weights	Kg/Lb	200Kgs / 440Lbs	290Kgs / 639Lbs	330Kgs / 727Lbs	340Kgs / 749Lbs
Crated Weights	Kg/Lb	305Kgs / 672Lbs	435Kgs / 959Lbs	510Kgs / 1124Lbs	535Kgs / 1179Lbs

\* DIMENSIONS ARE WITHOUT SIDE PANELS

\* Manufacturer reserves the right to change specifications without notice. Not responsible for error and omissions.



361-367 Beach Road, Burlingame, CA 94010  
 Tel: 855.885.2400 | 650.342.2400 | Fax: 650.342.7400  
 sales@oscartek.com | www.oscartek.com



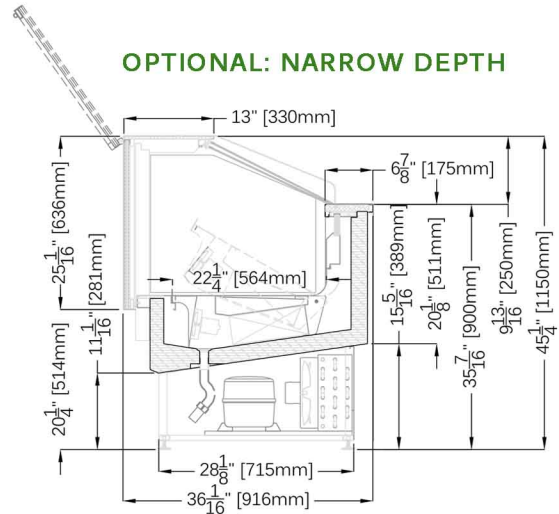
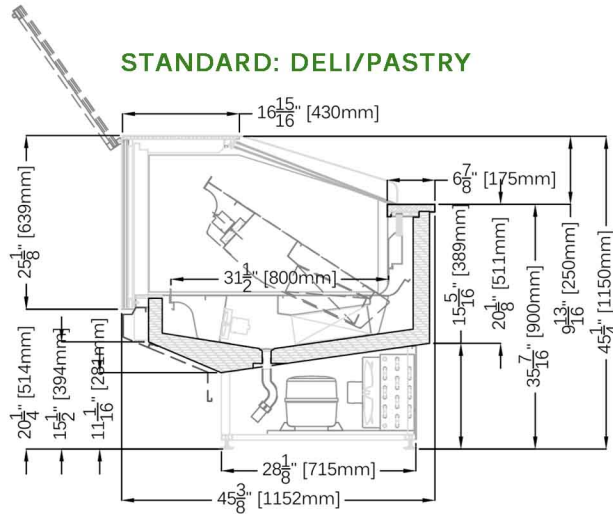

**PLAN VIEWS: LA CROSSE DP1150, LA CROSSE DP1650, LA CROSSE DP2150, LA CROSSE DPA90**

**LA CROSSE LINEAR MODELS**

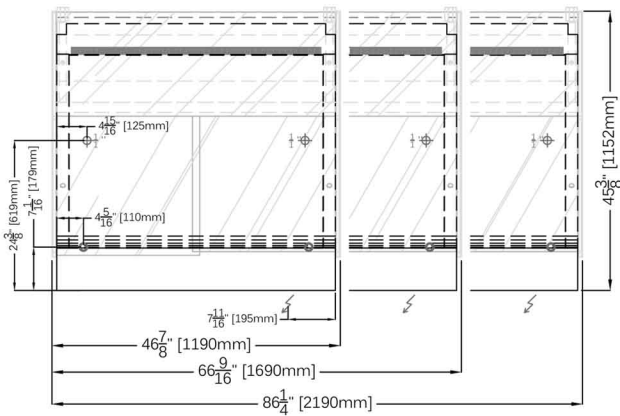

**LA CROSSE DPA90**

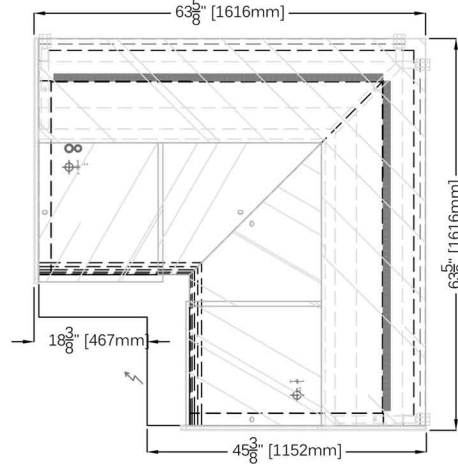

**REAR ELEVATIONS (OPERATOR SIDE): LA CROSSE DP1150, LA CROSSE DP1650, LA CROSSE DP2150, LA CROSSE DPA90**

**LA CROSSE LINEAR MODELS**

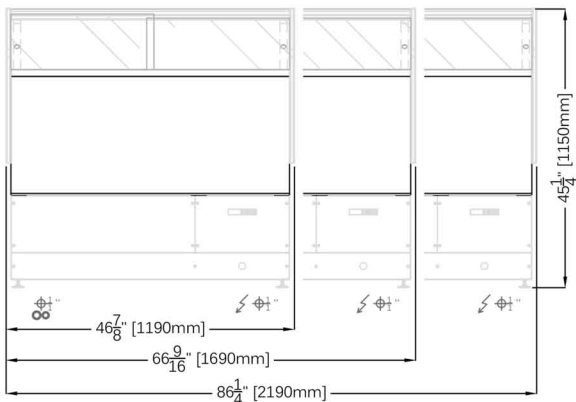

**LA CROSSE DPA90**

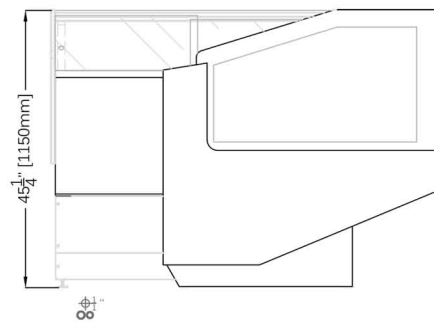

ELECTRICAL LEGEND	
	REFRIGERATED LINES
	DRAIN
	POWER

\* Manufacturer reserves the right to change specifications without notice. Not responsible for error and omissions.



361-367 Beach Road, Burlingame, CA 94010  
 Tel: 855.885.2400 | 650.342.2400 | Fax: 650.342.7400  
 sales@oscartek.com | www.oscartek.com

