

STANDARD FEATURES

- Double pane lift-up front glass
- Double pane sides
- Lift-up deck to allow the perfect cleaning of the tank
- Diffused LED lighting 3000°K
- Plexiglass sliding doors
- Cases ship standard unfinished

OPTIONS

- Bumper addition for cart/trolley
- Rolling curtain
- Paper holder
- Pull-out faucet inside the tank
- Cutting board with knives pocket
- Scale holder
- Intermediate shelf
- RAL color/laminate front and side panels
- Casters

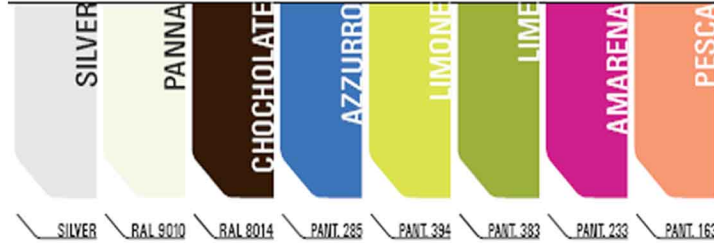

LA CROSSE NEUTRAL					
TECHNICAL FEATURES		MODELS			
		LA CROSSE N1150	LA CROSSE N1650	LA CROSSE N2150	LA CROSSE NA90
External Dimensions (L-D-H)	Inches	*46 7/8" - 45 3/8" - 45 1/4"	*66 9/16" - 45 3/8" - 45 1/4"	*86 1/4" - 45 3/8" - 45 1/4"	*63 5/8" - 45 3/8" - 45 1/4"
	Inches-MM	*1190 - 1152 - 1150	*1690 - 1152 - 1150	*2190 - 1152 - 1150	*1616 - 1152 - 1150
Crated Dimensions (L-D-H)	Inches	53 7/8" - 53 7/8" - 55 1/8"	73 5/8" - 53 7/8" - 55 1/8"	93 1/4" - 53 7/8" - 55 1/8"	70" - 53 7/8" - 55 1/8"
	Inches-MM	1370 - 1370 - 1400	1870 - 1370 - 1400	2368 - 1370 - 1400	1778 - 1370 - 1400
Electric Supply		230/1/50 (UE)	230/1/50 (UE)	230/1/50 (UE)	230/1/50 (UE)
	(V/Ph/Hz)	120/1/60 (USA)	120/1/60 (USA)	120/1/60 (USA)	120/1/60 (USA)
Power Consumption	(A)	2A	2A	3A	3A
Operating Temperature	Type	Ambient	Ambient	Ambient	Ambient
Net Weights	Kg/Lb	175Kgs / 385Lbs	270Kgs / 594Lbs	310Kgs / 682Lbs	330Kgs / 726Lbs
Crated Weights	Kg/Lb	220Kgs / 445Lbs	290Kgs / 640Lbs	340Kgs / 750Lbs	380Kgs / 835Lbs

* DIMENSIONS ARE WITHOUT SIDE PANELS

* Manufacturer reserves the right to change specifications without notice. Not responsible for error and omissions.



361-367 Beach Road, Burlingame, CA 94010
 Tel: 855.885.2400 | 650.342.2400 | Fax: 650.342.7400
 sales@oscartek.com | www.oscartek.com



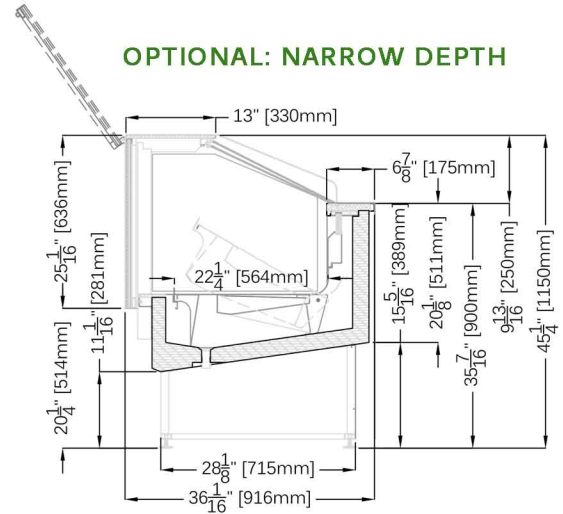
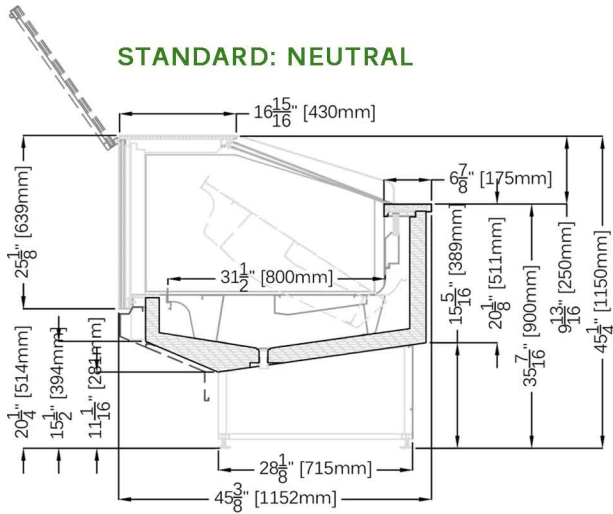

PLAN VIEWS: LA CROSSE N1150, LA CROSSE N1650, LA CROSSE N2150, LA CROSSE NA90

LA CROSSE LINEAR MODELS

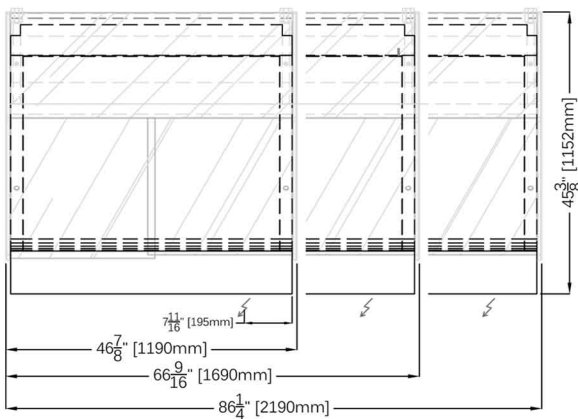

LA CROSSE NA90

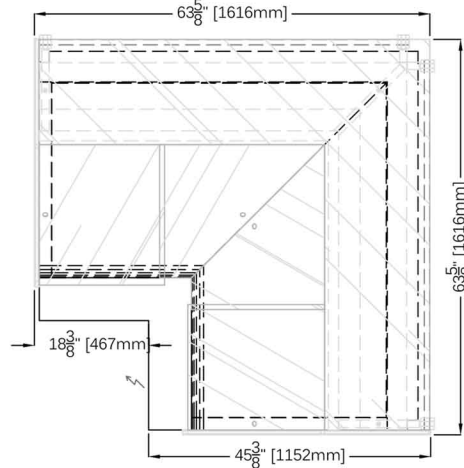

REAR ELEVATIONS (OPERATOR SIDE): LA CROSSE N1150, LA CROSSE N1650, LA CROSSE N2150, LA CROSSE NA90

LA CROSSE LINEAR MODELS

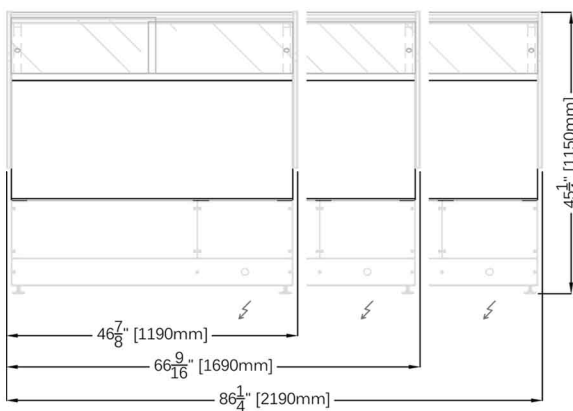

LA CROSSE NA90

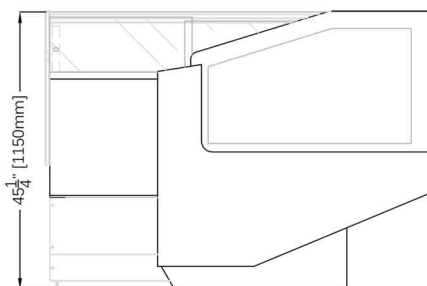

ELECTRICAL LEGEND	
	POWER

* Manufacturer reserves the right to change specifications without notice. Not responsible for error and omissions.



361-367 Beach Road, Burlingame, CA 94010
 Tel: 855.885.2400 | 650.342.2400 | Fax: 650.342.7400
 sales@oscartek.com | www.oscartek.com

