

LA CROSSE

Self Serve Showcase

STANDARD FEATURES

- Double pane sides
- Lift-up deck and evaporator to allow the perfect cleaning of the tank (self serve A1 models)
- Internal condensing unit except A2 A90
- Cases ship standard unfinished

OPTIONS

- Bumper addition for cart/trolley
- Paper holder
- Pull-out faucet inside the tank
- Cutting board with knives pocket
- Scale holder
- External condensing unit
- RAL color/laminate front and side panels
- Casters

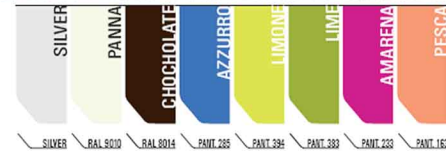
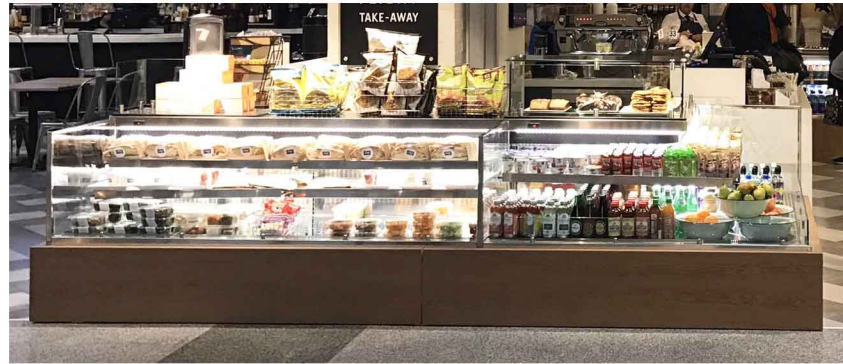

LA CROSSE SELF SERVE A1 (SELF CONTAINED)

TECHNICAL FEATURES		MODELS			
		LA CROSSE SS A1 1150	LA CROSSE SS A1 1650	LA CROSSE SS A1 2150	LA CROSSE SS A1 A90
External Dimensions (L-D-H)	Inches	*46 7/8" - 45 3/8" - 37 5/16"	*66 9/16" - 45 3/8" - 37 5/16"	*86 1/4" - 45 3/8" - 37 5/16"	*63 5/8" - 45 3/8" - 37 5/16"
	MM	*1190 - 1152 - 948	*1690 - 1152 - 948	*2190 - 1152 - 948	*1615 - 1152 - 948
Crated Dimensions (L-D-H)	Inches	53 7/8" - 53 7/8" - 43 1/8"	73 5/8" - 53 7/8" - 43 1/8"	93 1/4" - 53 7/8" - 43 1/8"	70 7/8" - 53 7/8" - 43 1/8"
	MM	1370 - 1370 - 1094	1870 - 1370 - 1094	2368 - 1370 - 1094	1800 - 1370 - 1094
Refrigerated Display Area	Type	Deck	Deck	Deck	Deck
Operating Temperature	°F	41°F	41°F	41°F	41°F
Compressor	Nr./Type	Hermetic	Hermetic	Hermetic	Hermetic
BTU'S @ +14°F Evap Temperature	BTU'S	3900 BTU'S	4600 BTU'S	5200 BTU'S	6800 BTU'S
Electric Supply	(V/Ph/Hz)	208-220/1/60	208-220/1/60	208-220/1/60	208-220/1/60
Power Consumption	(A)	10A	12A	14A	14A
Defrost	Mode/Type	Electric	Electric	Electric	Electric
Climatic Class	N°°C/F°/H.R.	3/24/77/55%	3/24/77/55%	3/24/77/55%	3/24/77/55%
Refrigerant Gas	Type	R404A	R404A	R404A	R404A
Net Weights	Kg/Lb	150Kgs / 330Lbs	240Kgs / 528Lbs	290Kgs / 638Lbs	340Kgs / 749Lbs
Crated Weights	Kg/Lb	175Kgs / 384Lbs	250Kgs / 550Lbs	340Kgs / 750Lbs	485Kgs / 1000Lbs

* DIMENSIONS ARE WITHOUT SIDE PANELS

* Manufacturer reserves the right to change specifications without notice. Not responsible for error and omissions.



361-367 Beach Road, Burlingame, CA 94010
 Tel: 855.885.2400 | 650.342.2400 | Fax: 650.342.7400
 sales@oscartek.com | www.oscartek.com



LA CROSSE SELF SERVE A2 (REMOTE)

TECHNICAL FEATURES		MODELS			
		LA CROSSE SS A2 1150	LA CROSSE SS A2 1650	LA CROSSE SS A2 2150	LA CROSSE SS A2 A90
External Dimensions (L-D-H)	Inches	*46 7/8" - 40 13/16" - 34 5/8	*66 9/16" - 40 13/16" - 34 5/8	*86 1/4" - 40 13/16" - 34 5/8	*64 15/16" - 40 13/16" - 34 5/8"
	MM	*1190 - 1036 - 880	*1690 - 1036 - 880	*2190 - 1036 - 880	*1650 - 1036 - 880
Crated Dimensions (L-D-H)	Inches	53 7/8" - 46" - 40"	73 5/8" - 46" - 40"	93 1/4" - 46" - 40"	70 7/8" - 46" - 40"
	MM	1370 - 1168 - 1016	1870 - 1168 - 1016	2368 - 1168 - 1016	1800 - 1168 - 1016
Refrigerated Display Area	Type	Deck	Deck	Deck	Deck
Operating Temperature	°F	41°F	41°F	41°F	41°F
Compressor	Nr./Type	Hermetic	Hermetic	Hermetic	Hermetic
BTU'S @ +14°F Evap Temperature	BTU'S	5680 BTU'S	6520 BTU'S	7210 BTU'S	8500 BTU'S
Electric Supply	(V/Ph/Hz)	208-220/1/60	208-220/1/60	208-220/1/60	208-220/1/60
Power Consumption (Remote)	(A)	2A	3A	4A	5A
Defrost	Mode/Type	Electric	Electric	Electric	Electric
Climatic Class	N°°C/F°/H.R.	3/24/77/55%	3/24/77/55%	3/24/77/55%	3/24/77/55%
Refrigerant Gas	Type	R404A	R404A	R404A	R404A
Net Weights	Kg/Lb	150Kgs / 330Lbs	240Kgs / 528Lbs	290Kgs / 638Lbs	390Kgs / 850Lbs
Crated Weights	Kg/Lb	175Kgs / 384Lbs	250Kgs / 550Lbs	340Kgs / 750Lbs	535Kgs / 1179Lbs

* DIMENSIONS ARE WITHOUT SIDE PANELS

SELF SERVE A1 - SELF CONTAINED

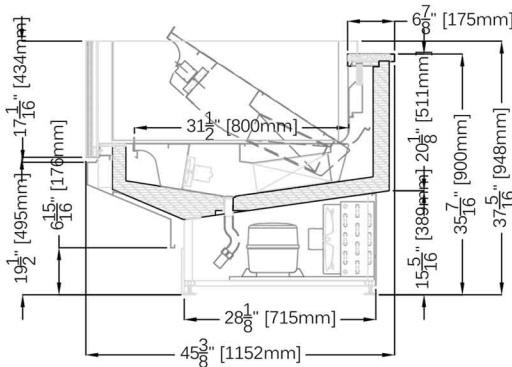

SELF SERVE A2 - REMOTE

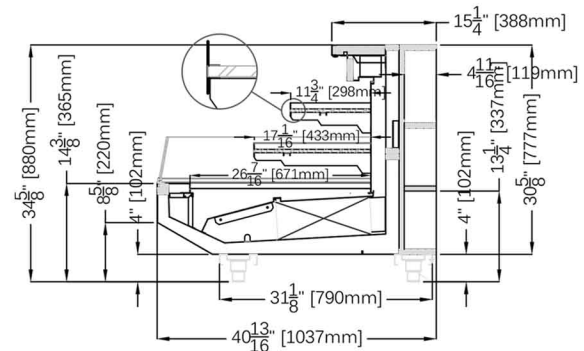

OPTIONAL - NARROW DEPTH

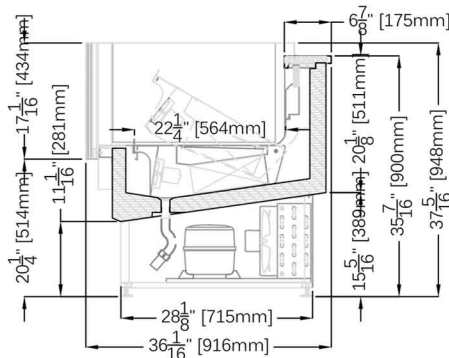

* Manufacturer reserves the right to change specifications without notice. Not responsible for error and omissions.



361-367 Beach Road, Burlingame, CA 94010
 Tel: 855.885.2400 | 650.342.2400 | Fax: 650.342.7400
 sales@oscartek.com | www.oscartek.com



SELF SERVE A1 - SELF CONTAINED

PLAN VIEWS: LA CROSSE SS A1 1150, LA CROSSE SS A1 1650, LA CROSSE SS A1 2150, LA CROSSE SS A1 A90

SELF SERVE A1 - LINEAR MODELS

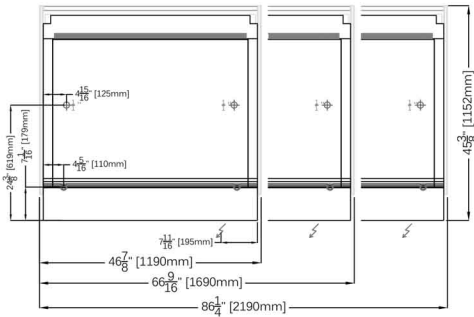

SELF SERVE A1 A90

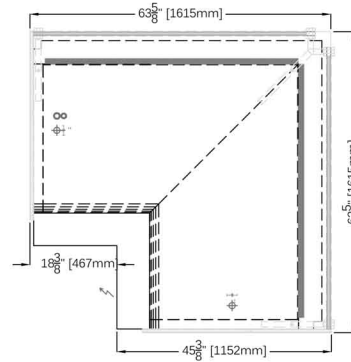

REAR ELEVATIONS (OPERATOR SIDE):

LA CROSSE SS A1 1150, LA CROSSE SS A1 1650, LA CROSSE SS A1 2150, LA CROSSE SS A1 A90

SELF SERVE A1 - LINEAR MODELS

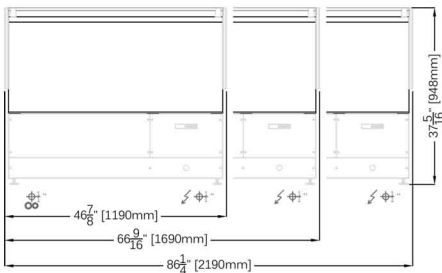

SELF SERVE A1 A90

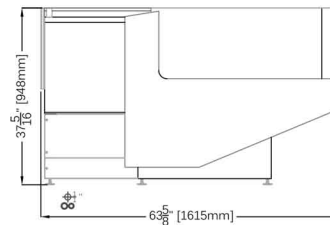

ELECTRICAL LEGEND

	REFRIGERATED LINES
	DRAIN
	POWER

* Manufacturer reserves the right to change specifications without notice. Not responsible for error and omissions.



361-367 Beach Road, Burlingame, CA 94010
 Tel: 855.885.2400 | 650.342.2400 | Fax: 650.342.7400
 sales@oscartek.com | www.oscartek.com



SELF SERVE A2 - REMOTE

PLAN VIEWS: LA CROSSE SS A2 1150, LA CROSSE SS A2 1650, LA CROSSE SS A2 2150, LA CROSSE SS A2 A90

SELF SERVE A2 - LINEAR MODELS

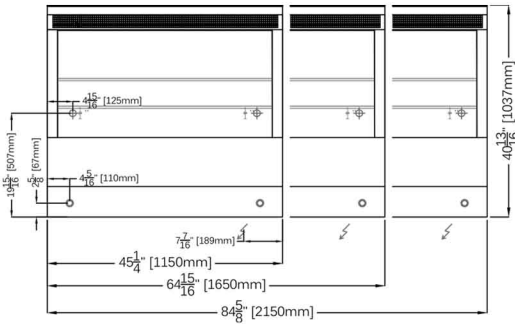

SELF SERVE A2 A90

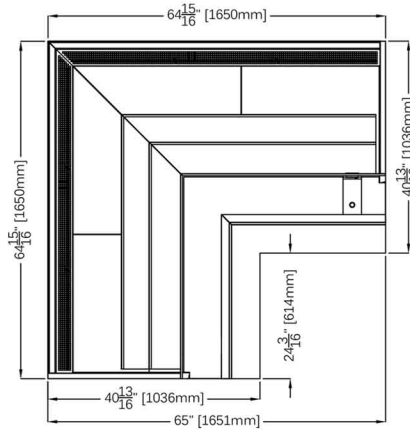

REAR ELEVATIONS (OPERATOR SIDE):

LA CROSSE SS A2 1150, LA CROSSE SS A2 1650, LA CROSSE SS A2 2150, LA CROSSE SS A2 A90

SELF SERVE A2 - LINEAR MODELS

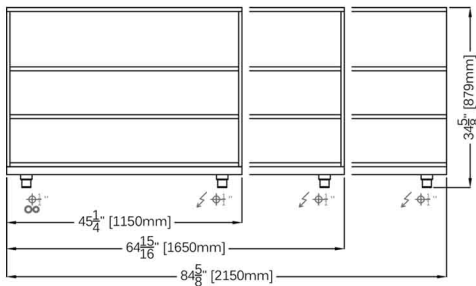

SELF SERVE A2 A90

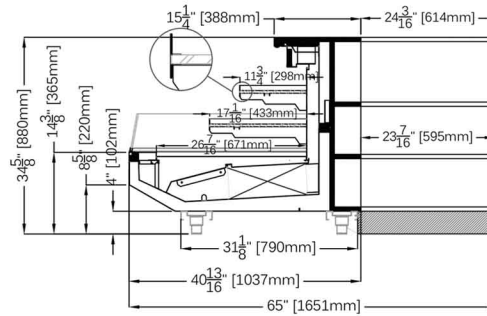

ELECTRICAL LEGEND

∞	REFRIGERATED LINES
$\phi \frac{1}{2}$ "	DRAIN
\swarrow	POWER

* Manufacturer reserves the right to change specifications without notice. Not responsible for error and omissions.



361-367 Beach Road, Burlingame, CA 94010
 Tel: 855.885.2400 | 650.342.2400 | Fax: 650.342.7400
 sales@oscartek.com | www.oscartek.com

