

CS (DRY)

METRO 1 - 47 1/4"H

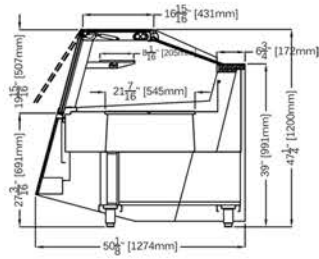

METRO 2 - 54 5/16"H

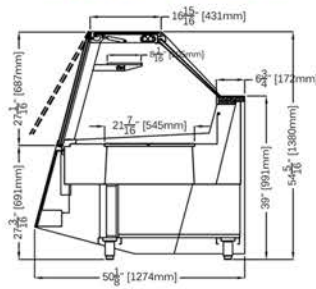

METRO 3 - 61 3/16"H

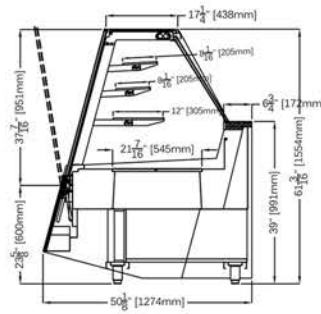

CBM (BAIN MARIE)

METRO 1 - 47 1/4"H

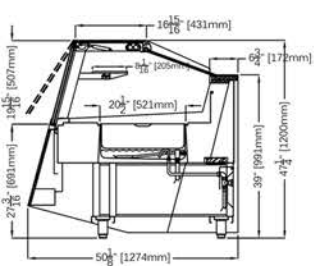

METRO 2 - 54 5/16"H

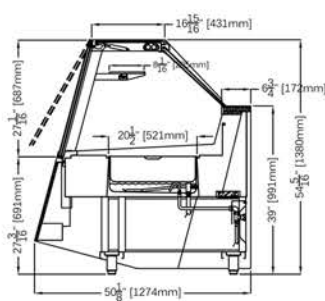

METRO 3 - 61 3/16"H

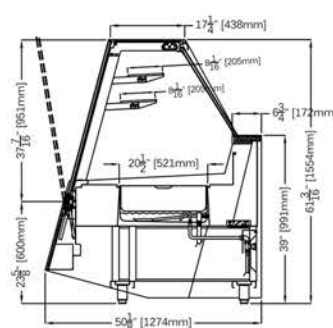

STANDARD FEATURES

- LED lighting system
- Front, top and side double glasses
- CS: dry warm top on stainless steel basin
- CBM: hot well food warmer
- Cases ship standard unfinished

OPTIONS

- Self-rolling night curtain
- S/s steps for display area
- Casters
- Heated glass shelf with digital control
- Available heights: 47.25"H & 54"H with one shelf, CS 59.50"H with three shelves, CBM 59.50" with two shelves

CBM (BAIN MARIE) LAYOUTS:

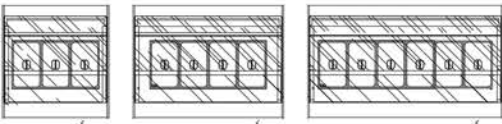

METRO HOT (CS - DRY)				
TECHNICAL FEATURES		MODELS		
		METRO 2 CS1150	METRO 2 CS1650	METRO 2 CS2150
External Dimensions (L-D-H)	Inches	45 1/4" - 50 1/8" - 54 5/16"	64 15/16" - 50 1/8" - 54 5/16"	84 5/8" - 50 1/8" - 54 5/16"
	MM	1150 - 1274 - 1380	1650 - 1274 - 1380	2150 - 1274 - 1380
Crated Dimensions (L-D-H)	Inches	51 1/4" - 55 1/4" - 60"	70" - 55 1/4" - 60"	90" - 55 1/4" - 60"
	MM	1301 - 1403 - 1524	1778 - 1403 - 1524	2286 - 1403 - 1524
Power Supply	(V)	220V	220V	220V
Power Consumption	(A)	500W	1000W	1210W
Operating Temperature	°C / °F	80°C / 177°F	80°C / 177°F	80°C / 177°F
Net Weights	Kg/Lb	104Kgs / 239Lbs	144Kgs / 331Lbs	188Kgs / 432Lbs
Crated Weights	Kg/Lb	124Kgs / 285Lbs	170Kgs / 391Lbs	205Kgs / 470Lbs

* Dimensions are without side panels & with Metro 2 information

METRO HOT (CBM - BAIN MARIE)				
TECHNICAL FEATURES		MODELS		
		METRO 2 CBM1150	METRO 2 CBM1650	METRO 2 CBM2150
External Dimensions (L-D-H)	Inches	45 1/4" - 50 1/8" - 54 5/16"	64 15/16" - 50 1/8" - 54 5/16"	84 5/8" - 50 1/8" - 54 5/16"
	MM	1150 - 1274 - 1380	1650 - 1274 - 1380	2150 - 1274 - 1380
Crated Dimensions (L-D-H)	Inches	51 1/4" - 55 1/4" - 60"	70" - 55 1/4" - 60"	90" - 55 1/4" - 60"
	MM	1301 - 1403 - 1524	1778 - 1403 - 1524	2286 - 1403 - 1524
Power Supply	(V)	220V	220V	220V
Power Consumption	(A)	1500W	2030W	3040W
Operating Temperature	°C / °F	80°C / 177°F	80°C / 177°F	80°C / 177°F
Net Weights	Kg/Lb	104Kgs / 239Lbs	144Kgs / 331Lbs	188Kgs / 432Lbs
Crated Weights	Kg/Lb	124Kgs / 285Lbs	170Kgs / 391Lbs	205Kgs / 470Lbs

* Dimensions are without side panels & with Metro 2 information